

LA100 Application Note 16 Fitting a Backlit Display

Since June 1993 new LA100 Audio Analysers have been supplied with high contrast backlit displays. An upgrade kit (order code BKLK) is available so that existing users can take advantage of this improvement. Units may also be returned to the factory to be upgraded (order code BKLF).

Overview

The modifications for an LA101 are the same as for an LA102. To carry them out takes about 2 hours for an LA100 (i.e. changing 2 displays). No special tools are required. The main steps are:

1. Dismantling
2. Fitting the new display
3. Top PCB modifications
4. Reassembly
5. Testing

The procedure for a single unit is described below. You are strongly advised to read through this entire document before commencing any work. Please telephone Lindos if you have any difficulties. Note that all memory contents (test results, tolerance and sequence definitions, configurations) will be lost.

Any tolerance definitions can be printed by entering the tolerance editor (press [ON/OFF][1]) and then pressing [*][PRINT]. LA102 configurations can be printed by entering the configuration menu (press [ON/OFF][2]) and then pressing [*][PRINT]. Results can be printed by first putting the results into memory 0 if necessary, and then pressing [*][PRINT].

Upgrade Kit

Check that your upgrade kit contains the following parts:

| | | |
|---|------------------------|-----------------------|
| 2 x LCD Displays | 2 x mains transformers | 2 x bridge rectifiers |
| 8 x screws | 2 x wire links | 8 x nylon washers |
| 2 x 6R8 resistors | 2 x 14cm Kynar wire | 2 x 26 way connectors |
| 4 x diodes 11DQ03 (2 long + 2 pre-formed) | | |

Safety Precautions

Unplug the unit from the mains supply before carrying out any modification. The LCD displays are static sensitive when unconnected and should be handled appropriately.

Dismantling

- Unplug all cables to external equipment.
- Remove the covers, and if the unit is a LA100R, separate the LA101 and LA102 by undoing the 4 coupling bolts.

- Unplug and unscrew the battery and remove it from the unit.
- Unplug the three ribbon cable connectors at the front of the top PCB (PL1, PL2 & PL3).
- Remove the 4 screws retaining the top PCB.
- Remove the 2 screws retaining the mains inlet unit and 1 screw retaining the earthing conductor.
- Remove the top PCB (with mains inlet unit attached).
- Remove the ribbon cable connecting the front jack sockets to PL7 at the front of the bottom PCB
- Unscrew the 4 screws which fix the front panel to the chassis.
- Carefully ease the front panel ribbon cables through the slots in the chassis and remove the front panel.
- Unscrew the 4 LCD fixing screws and remove it from the panel.
- Fitting a Backlit Display

Fitting the New Display

- Place a nylon washer on top of each of the 4 LCD support pillars on the front panel.
- Remove the protective film from the display. Ensure LCD glass and front panel glass are clean.
- Without disturbing the washers, set the display on the support pillars with its connector closest to the keyboard PCB.
- Fix the display to the front panel with four of the screws supplied. After turning each screw 2-3 times check that the washers are in position and re-fit if necessary. Tighten the screws but **do not overtighten or the front panel will crack**.
- Set the front panel aside, and put the old LCD into the conductive bag supplied with the new display.

Top PCB modifications

- Unscrew the plastic safety cover from the bottom of the PCB Make a note of where the brown and blue wires are connected to the PCB, then unsolder these wires.
- Unsolder and remove the mains transformer TR1, the bridge rectifier D4, D10 and R3.
- Unsolder PL1. Take care not to damage the PCB. Do not worry about damaging PL1 - a new one is supplied. If you do not have access to a desoldering station, we recommend the following method:
 - Apply a soldering iron to pin 1's soldered connection while gripping the other end of the pin with fine pliers. When the solder melts the pin can easily be pulled from the housing. Repeat for other pins.
- Clean up the holes with a solder removing tool. Identify holes 25 and 26. These are the two closest to C6. They are connected together by copper track on both sides of the PCB. Break these connections. There are various techniques that can be used. Careful use of a scalpel is satisfactory, as is careful use of a small end mill on a bench drill.

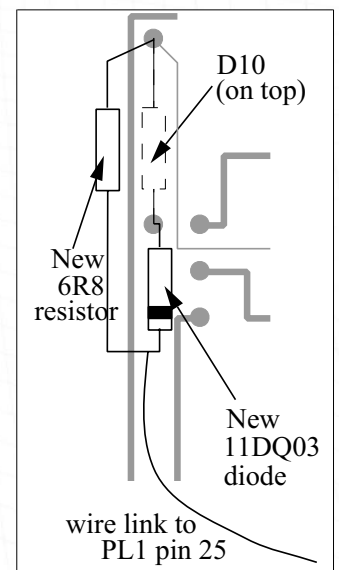

- Using an ohmmeter, confirm that holes 25 & 26 are not connected, and hole 26 (the one nearest the back) is connected to pin 3 of IC18 (IC18 is on a heat sink, and pin 3 is nearest the back of the PCB).
- Solder a new 26 way connector into position PL1. Ensure the notch faces forward (like PL2).
- Solder the new transformer into place.
- Solder the preformed 11DQ03 into position D10 ensuring it is inserted with correct polarity. (Band on diode to '-' on PCB)
- Solder a preformed wire link into position R3
- Solder a new bridge rectifier CH228 into position D4, ensuring it is inserted with correct polarity. ('+' on component to '+' on PCB)
- Solder the 6R8 resistor and remaining 11DQ03 diode to the bottom of the PCB as follows:
 - Solder the anode of the new diode to the anode of D10. (The band on the diode body identifies the cathode.)
 - Solder one end of 6R8 to the cathode of D10.
 - Solder together the free ends of the new components.
 - Connect the junction of the new components to PL1 pin 25 using the insulated silver wire supplied.
 - Tack the wire in place with super glue and clean the flux residue from the PCB.
 - Solder the IEC mains inlet onto the PCB with the brown and blue wires arranged as they were at the start.

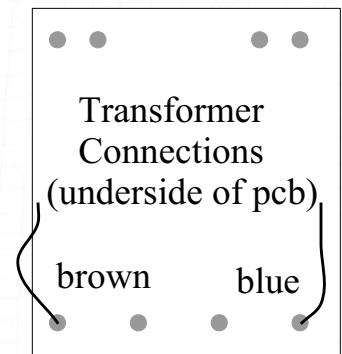

Replace the plastic cover over the mains connections to the transformer.

Reassembly

- Feed the ribbon cables from the front panel through the slots in the chassis. The new display cable needs a twist. The twist should be made so that it is between the front panel and the chassis.
- Fit the front panel to the chassis with the 4 original screws. **Do not overtighten or the front panel will crack.**
- Attach the earthing conductor to the chassis with the original screw, nut and two shakeproof washers, one either side of the solder tag.
- Replace the IEC mains inlet unit with the original screws and nuts. The centre pin of the connector should be closest to the top of the chassis.
- Place the top board in position. Ensure the new resistor and diode do not foul the chassis and adjust their position if necessary. Finally check the wiring of the new bottom board modifications, then screw the board into place.
- Replace all the ribbon cable connectors.
- Replace the battery, **but do not connect yet.**

Testing

With an ohmmeter check the following:

- IEC mains connector to chassis should be short circuit.*
- IEC connector live to neutral should be about 695W.*
- Live to chassis and neutral to chassis should be open circuit.*
- Chassis to each end of D10 should be open circuit.
- Cathode of D10 to PL1 pin 25 should be 6R8.
- PL1 pin 25 to PL1 pin 26 should be about 55kW.

- PL1 pin 26 to IC18 pin 3 (rearmost pin) should be short circuit.

* These three tests are to check the safety of the equipment. If you are in doubt about the results **do not connect the equipment to the mains supply**. Contact Lindos Electronics for advice.

If all the tests give the correct result connect the battery, and switch on.

Operation

The display should appear as normal, but with improved contrast and viewing angle. You may need to make adjustment for best contrast using the contrast control on the top PCB. You can now replace the covers. If the ambient lighting is very bright you may not notice the backlight, but it will be apparent in areas with dim ambient lighting.

In cold conditions (<8°C) the response of the LCD on first switching on is a little slow, but this effect disappears after about 15 minutes, because the LCD module is warmed by the backlight.

The brightness of the light depends on the state of charge of the battery, and will be brightest when the unit is supplied with mains, and the battery is well charged. The light will be dim if the battery is discharged, and may not operate at all if the battery has a shorted cell although the unit will appear to function correctly in all other ways.

When working on batteries, the light will be satisfactory for about 1 hour if the battery was in good condition and well charged to start with. The light will still be useable for a further 30 minutes in very dim conditions, and the unit will continue to function for a further 3 - 4 hours after the light has gone (ie 4½-5½ hours in total). The time taken to fully charge a flat battery has gone up from 24 hours to 36 hours.

If you have no other use for the old display module, please return it to Lindos.

Technical data

The backlight configuration is shown below, and this circuit should be compared with that of the original circuit in the LA100 manual fourth edition, page 177.

The additional current for the light would overload the original transformer, so the new transformer secondary winding has a 26% greater current rating, but a 20% lower voltage rating. The voltage loss is made up by the new custom bridge rectifier which has a voltage drop of 1 Volt compared with 2 Volts for the original rectifier.

In battery operation, the backlight takes its supply via the new diode, D11. In mains operation, the light supply is via the new resistor, R4.

R3 has been replaced with a short circuit to ensure adequate charging current, particularly if the mains voltage is less than 225V.

In the original design, PL1 pin 25 carried +5 Volts for an unused connection on the LCD. It now carries the backlight current.

19.09.1997

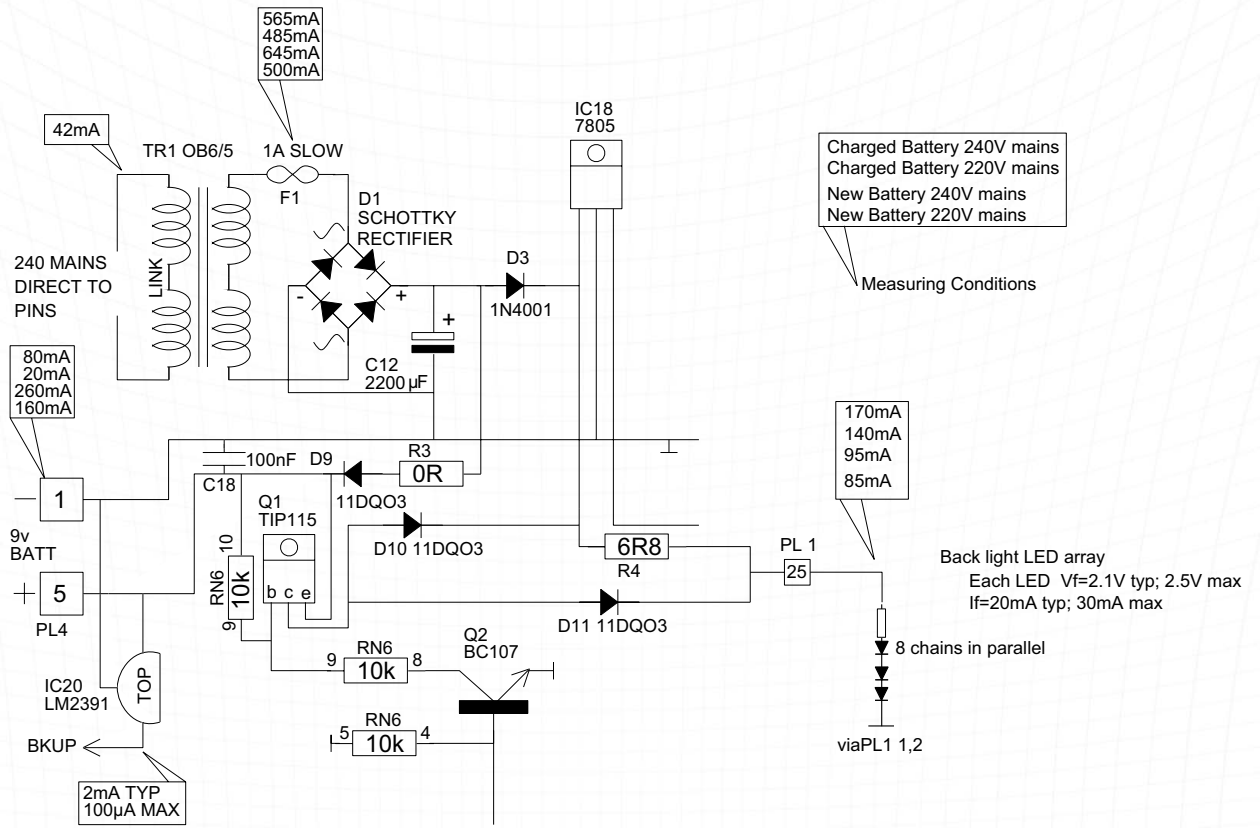

Andy Barkley